

(No Model.)

P. J. KELLY & J. GROVES.

ADJUSTABLE REAMER.

No. 321,116.

Patented June 30, 1885.

Fig. 1.

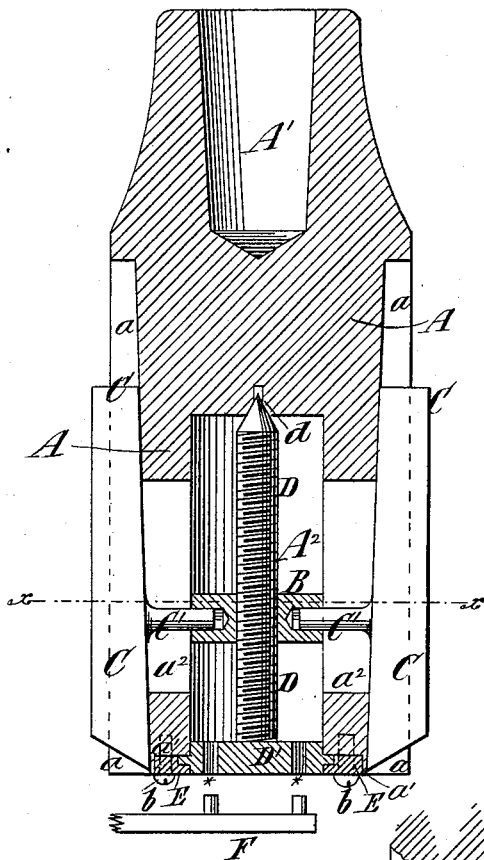

Fig. 3.

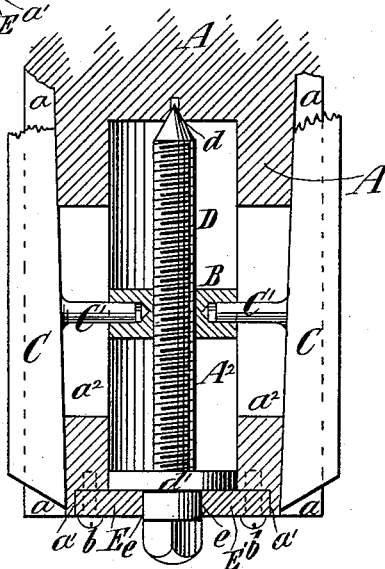
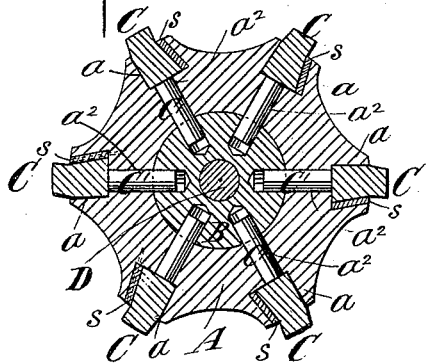

Fig. 2.



Witnesses:
 Emil Herter.
 Henry M. Bride

Inventors.
 Patrick J. Kelly
 James Groves
 by James M. Allen
 Brown & Hall

UNITED STATES PATENT OFFICE.

PATRICK J. KELLY AND JAMES GROVES, OF BROOKLYN, NEW YORK.

ADJUSTABLE REAMER.

SPECIFICATION forming part of Letters Patent No. 321,116, dated June 30, 1885.

Application filed May 5, 1885. (No model.)

To all whom it may concern:

Be it known that we, PATRICK J. KELLY and JAMES GROVES, both of the city of Brooklyn, in the county of Kings and State of New York, have invented a new and useful Improvement in Adjustable Reamers, of which the following is a specification.

Our invention relates to cylindric and taper reamers, which consist of a shell or body provided with longitudinal grooves or seats for cutters, and cutters fitting in such grooves or seats and adjustable therein.

The object of our invention is to provide a convenient means whereby cutters of the kind described may be adjusted upon the shell or body of a reamer so as to compensate for wear, and maintain the uniform or standard size of holes finished by the reamer; and the invention consists in a novel combination, with the shell or body of a reamer and cutters, of devices, hereinafter described, for adjusting the cutters simultaneously in a direction lengthwise of the shell or body.

In the accompanying drawings, Figure 1 represents an axial section of a reamer embodying our invention. Fig. 2 represents a transverse section on the plane of the dotted line *x x*, Fig. 1; and Fig. 3 represents an axial section of a reamer embodying our invention in a slightly modified form.

Similar letters of reference designate corresponding parts in the several figures.

A designates the shell or body of a reamer, which may be of steel or iron, and which has in its upper end a cavity or socket, A', whereby it may be secured upon the spindle of a lathe or drill-press. In the shell or body A are a number of longitudinal grooves, *a*, extending throughout the cylindric portion of the shell or body. The bottoms of these grooves *a* are inclined or tapered toward the lower end of the shell or body—that is to say, at the lower end of the shell or body the grooves are of greater depth than at the upper end thereof.

In the grooves *a* are fitted steel cutters C, which may be moved or adjusted lengthwise of the grooves, and in order to retain these cutters in place the grooves and the portions of the cutters which fit therein are dovetailed, as best shown in Fig. 2. The cutters have a greater depth at their lower ends than at their

upper ends, and when placed in the grooves the outer edges of these cutters describe a circle of equal diameter at top and bottom of the reamer, if the reamer be a straight reamer; hence it will be seen that by adjusting the cutters lengthwise of the shell or body of the reamer the size of the reamer will be increased or diminished and the cylindric form of the reamer will be preserved.

In the lower end of the reamer is a cavity or recess, A², wherein is arranged a head or follower, B, which fits snugly in said cavity or socket, and is screw-threaded to receive through it a screw, D. As shown, this screw has an enlarged head or flange, D', and is held against the shell or body of the reamer by a cap, E, which is rabbeted on the inner side to receive the flange D', and fits in the rabbet *a'* in the end of the shell or body. This cap E may be secured on the shell or body of the reamer by screws *b*, or in any other suitable manner. At its inner end the screw D, which has a conical point, fits a bearing, *d*, in the shell or body of the reamer, and by such bearing and the cap or plate E the screw is held against axial movement in either direction, and may be readily turned to adjust the head or follower B lengthwise thereof.

Each of the cutters C has an inwardly-projecting stud or pin, C', which works in a slot, *a*², in the shell or body A, and which enters a socket in the head or follower B. Therefore it will be seen that these studs or pins C' prevent the head or follower B from turning, and when said head or follower is moved lengthwise of the reamer by turning the screw D it will carry with it the cutters C, and by adjusting them all simultaneously in a direction lengthwise of the reamer will vary the size of the reamer.

In the flange or head D' of the screw D are holes *; and F designates a wrench, which may be applied to said flange or head for turning the screw.

Instead of the means above described for holding the screw in place, and especially for reamers of smaller size, we may construct the screw with a collar, *d'*, as shown in Fig. 3, and the cap E', against the inner side of which the collar bears, has a hole or aperture, *e*, through which the shank of the screw, below the col-

lar, projects. The outer end of the screw will then have a square head upon which a wrench may be applied for turning the screw.

5 The slots a^2 might extend clear to the lower end of the shell or body in order that the cutters C, with their attached pins or studs C', may be slid lengthwise into place; but as this would weaken the shell or body we prefer that the slots a^2 shall terminate at some distance above its lower end. The grooves a 10 may then be made greater in width than the dovetailed tongues on the cutters and have fitted to them gibs s , as shown in Fig. 2. The cutters C may then be introduced laterally 15 into the grooves a , and the gibs s afterward slid in endwise to lock the cutters in place. The gibs may be held in place by pins inserted through them and entering the shell or body.

20 Our invention provides for very slightly varying the size of the reamer, to compensate for wear, or a greater adjustment, to adapt the reamer for cutting holes of different sizes.

What we claim as our invention, and desire to secure by Letters Patent, is—

25 1. The combination, with a reamer shell or body having longitudinal grooves and a cavity or recess, of cutters dovetailed into said

grooves and provided with inwardly-projecting pins or studs, a follower arranged within the recess or cavity of the shell or body and 30 receiving the pins or studs of the cutters, and a screw held against longitudinal movement within the shell or body, and engaging with said follower, and serving by its turning to adjust the cutters lengthwise of the shell or body, 35 substantially as herein described.

2. The combination, with the shell or body A, provided with longitudinal grooves or seats a , and having an internal recess or cavity, A^2 , of the cutters C, dovetailed into said grooves 40 or seats, and having inwardly-projecting pins or studs C', the head or follower B, receiving such pins or studs, and the screw D, the inner end of which has a bearing at d , which engages with said follower, and which has a 45 flanged head, and a cap applied to the end of the shell or body to retain the screw in place therein, substantially as herein described.

PATRICK J. KELLY.
JAMES GROVES.

Witnesses:

C. HALL.
FREDK. HAYNES.